

407 SERIES / WEAPONS PLATFORM

Product Information – Continuous Version



407 Series I Continuous Platform in aircraft shell

Cantine Armament Inc, proprietary rights are included in the information disclosed herein. Recipient by accepting this document agrees that neither this document nor the information disclosed herein nor any part thereof shall be reproduced or transferred to other documents or used or disclosed to others for manufacturing or any other purpose except as specifically authorized in writing by Cantine Armament Inc.



407 SERIES / WEAPONS PLATFORM



Product Information – Continuous Version

The ALWiP features a modular system design to be quickly reconfigured in order to support rapid deployments and flexible mission profiles. The system features an optional integrated external data and ICS ports to facilitate ground crew communication with aircrew and to interface with critical aircraft mission systems. 14" NATO standard 1,000 pound class ejector racks provided at the outboard stations to allow for installation of rocket and missile launchers, gun pods, external fuel cells, and many other standard payloads. Specially designed modular lightweight mounts are provided for gun systems such as the 7.62 M-134 "minigun" and .50 Caliber GAU-19A/B Gatling gun and are strategically located at several inboard attachment points. A cargo rail system has been integrated into the platform's inboard surface area to provide versatile mounting options for ammunition magazines and mission equipment. The floor system may be expanded to include the entire cabin area, creating a flat and unobstructed floor for utility or assault missions.

Features:

- Modular design allows for rapid mission configuration
- Optional Integrated Communications System (ICS) and data port
- 2 stations equipped with 14" NATO standard ejector racks
- Cargo rail system on center section for flexibility when securing cargo
- Optional modular floor provides additional cargo rails for added capacity

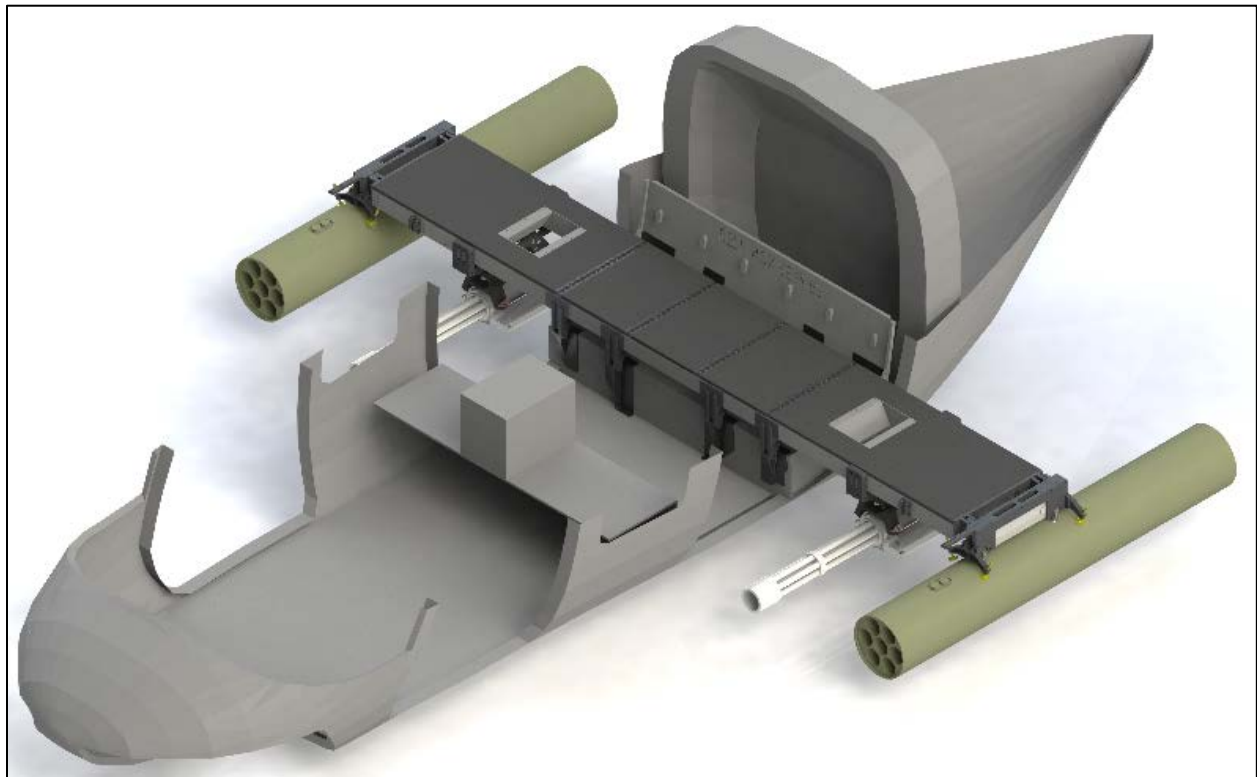

Cantine Armament Inc, proprietary rights are included in the information disclosed herein. Recipient by accepting this document agrees that neither this document nor the information disclosed herein nor any part thereof shall be reproduced or transferred to other documents or used or disclosed to others for manufacturing or any other purpose except as specifically authorized in writing by Cantine Armament Inc.

